

Bicolour level gauge type black-white

one sight opening, lateral connection, protective LED-light tube

Application and function

The bicolour level gauge black-white is a direct level gauge with illumination and can be used for steam generators. For best results, observe the liquid level standing directly in front of the sight opening.

In the sight opening, the height of the liquid level is indicated in black and the steam space in white. The product corresponds to the PED directive 97/23/EEC art. 3 par. 3 SEP (Sound Engineering Practice). Applied rules as per TRD/AD2000 or ASME-Boilers.

Possible video transmission of liquid level onto a monitor in the control room.

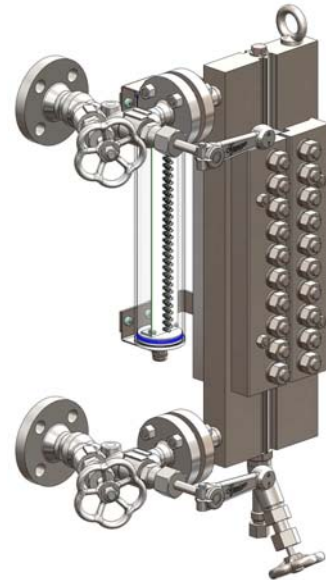

Technical basic equipment

- Body material carbon steel
- As left sided (mapped) or right sided model
- Sight length see table
- With drain valve and ventilation plug
- Illumination device IP67
- Shutoff valves type A220 and A240
- Drain valve type AV500, AV 520

Available (optional) versions

- Body material according to ASME
- Other drain valve

Technical data

All. pressure	PS [bar]	32	50	80	100	160	200
All. temp.	TS [° C]	239	265	296	312	348	367
Shutoff valve	Type	A220		A240			
	Data sheet	D-09-D-16356-1		D-09-D-16357-1			
Drain valve	Type	AV500	AV520				
	Data sheet	D-09-D-16358-0					

Illumination	
Protective LED-light tube	
IP67 230V / 50Hz oder 110-120V / 60Hz	
Without switch box	D-A1-D-18931-0
With standard switch box	D-A1-D-20722-0



Dimensions and tables

Left sided model

Right sided model

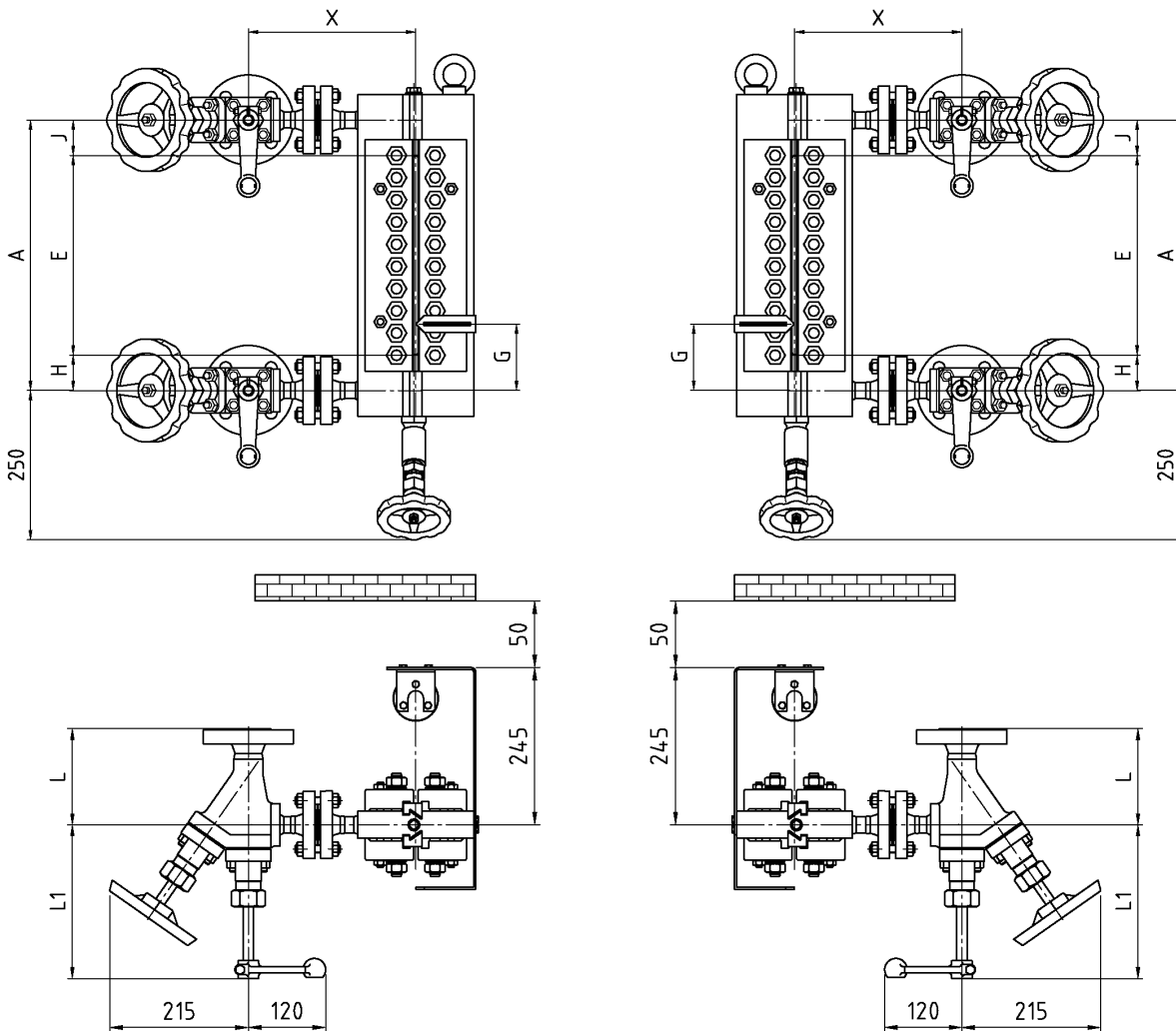

Size		7	8	9	10	11
Sight length	E	250	280	310	330	370
Dimension	H/J _{min} [mm]	25				
	H/J _{max} [mm]	on request				

Other sizes on request.



Information:

Depending on the size and version of the level gauge the customer has to arrange a sufficient brace support (eg. spring suspension etc.).





Allowable pressure PS [bar]	Valve	Flange	L [mm]	Welding end / Socket welding	L [mm]	X [mm]	L1 [mm]
32	A220	DN20	170	DN20		210	175
50	A150	DN25	130	DN25		220	175
80	A150	DN 25	130	DN25	130	220	175
80	A220	DN25	160	DN25	150/160	235	175
100	A240	DN25	145	DN25	150/160	245	240
160	A240	DN25	155	DN25	150/160	300	240
200	A240	DN25	170	DN25	150/160	300	240

