

Bypass level indicator, liquid gas/KOPlus version, model BNA-L

Bypass chamber from stainless steel

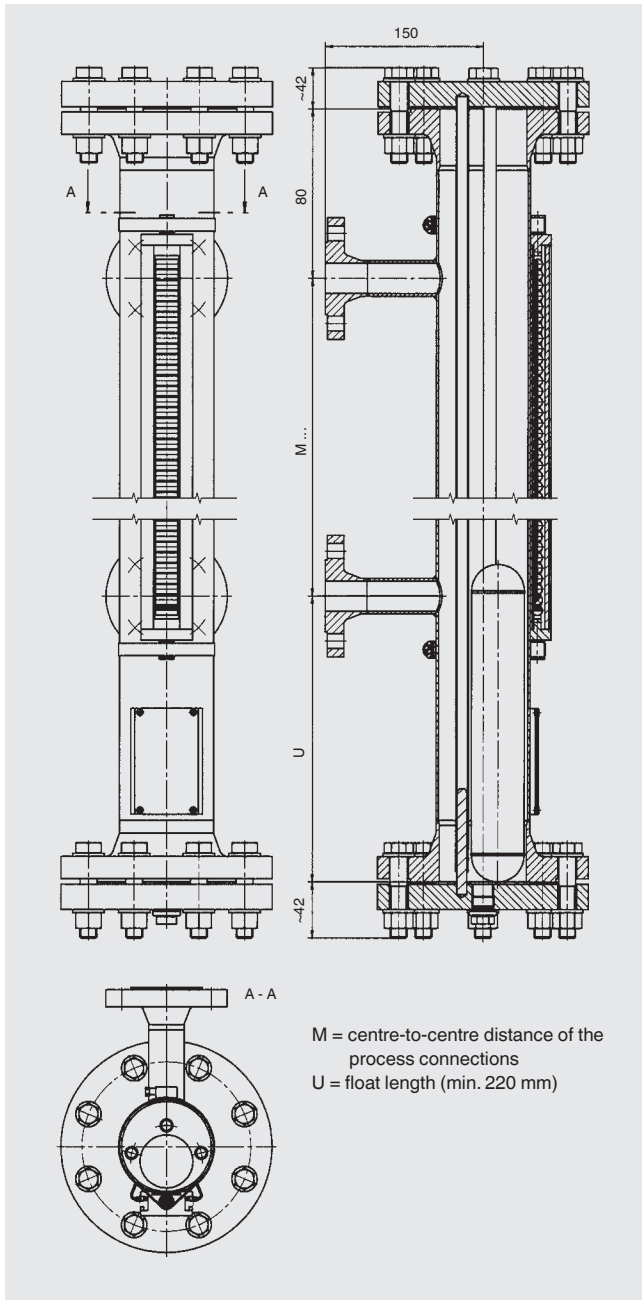

Specifications

Bypass chamber	<ul style="list-style-type: none"> Ø 88.9 x 2 mm, max. 25 bar Ø 88.9 x 2.9 mm, max. 40 bar
Chamber end top	<ul style="list-style-type: none"> Flange connection Options: (see page 14) <ul style="list-style-type: none"> ■ Vent screw ■ Vent valve ■ Vent flange
Chamber end bottom	<ul style="list-style-type: none"> Flange connection Options: (see page 14) <ul style="list-style-type: none"> ■ Drain plug ■ Drain valve ■ Drain flange
Process connections	<ul style="list-style-type: none"> 2 x lateral (options see page 15) Flange EN 1092-1, DN 10 - DN 100, PN 6 - PN 63 Flange DIN, DN 10 - DN 100, PN 6 - PN 64 Flange ANSI B 16.5, 1/2" - 4", class 150 - class 600 Weld stub 1/2" - 1" Threaded bushing G/NPT 1/2" - 1" Threaded nipple G/NPT 1/2" - 1"
Centre-to-centre distance	Min. 150 mm to max. 6,000 mm (larger distances on request)
Material	<ul style="list-style-type: none"> Stainless steel 1.4571 (316Ti) (Ø 88.9 x 2 mm, Ø 88.9 x 2.9 mm) Stainless steel 1.4404 (316L) (Ø 88.9 x 2 mm)
Nominal pressure	Max. 40 bar
Temperature range	-60 ... +300 °C
Float	Cylindrical float, model BFT-H, see data sheet LM 10.02
Magnetic display	<ul style="list-style-type: none"> Standard version, model BMD-S: < 200 °C High-temperature version, model BMD-F: > 200 °C, see data sheet LM 10.03
Level sensor	<ul style="list-style-type: none"> Reed sensor, model BLR, see data sheet LM 10.04 Magnetostrictive sensor, model BLM, see data sheet LM 10.05 Guided wave radar, model GTR (for KOPlus version), see data sheet LM 20.05
Magnetic switches	Magnetic switch, model BGU, see data sheet LM 10.06
Approvals	Ex c, GOST-R

Special versions on request

KOPlus version

