

Hydraulic Clamp Nut

Oil coupling system



Series 032 / 132

Features of series

**Tangential connected
oil pump**

**Medium remains into
the pump system**



The pressure is based by the connection with the oil pump.
The internal medium will flow into the circular groove and raise the ring piston.
Pressure rate is shown precisely at the pressure gauge.
Relieve the system results in pressure decrease inside the connected pump.
After relieve you have to turn the nut to the opposite direction .
The Medium flows back to the oil pump.

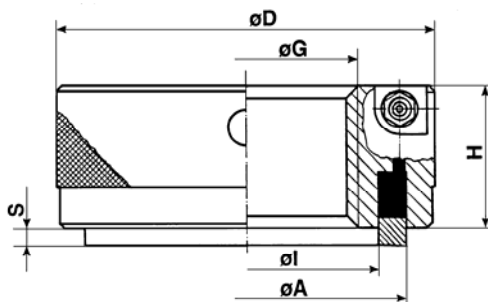

Clamping range
4 mm
6 mm
10 mm

Thread $\varnothing G_{max.}$	Ring piston		Outer Diameter $\varnothing D$	Height H	Clamping Force in kN Pump with max.working pressure		Part No Clamping range S
	$\varnothing A$	$\varnothing I$			400 bar	700 bar	
							4 mm
100	160	138	195	60	200	360	132.04.100
130	190	170	225	65	220	390	132.04.130
285	335	315	375	75	400	700	132.04.285
							6 mm
100	160	138	195	60	200	360	132.06.100
130	190	170	225	65	220	390	132.06.130
							10 mm
180	230	210	300	230	270	480	132.10.180
230	285	270	315	285	260	450	132.10.230

Against corrosion our hydraulic clamp nuts are protected with a brown finish.
The standard sealing systems are suitable for temperatures up to 80°.
The ring piston is locked against drop out.

Special design (for example Material - Aluminium hartcoatiert) on request



AVEMAR CZECH s.r.o. | speciální armatury pro měření a regulaci
Branch office | Lihovarská 1199/10 | 716 03 Ostrava - Radvanice | Česká republika
Tel.: +420 596 232 996 (7) | Fax: +420 596 232 998 | www.avemar.cz | avemar@avemar.cz