

DESCRIPTION

Solenoid valve 2 way normally closed
direct acting poppet type

CONSTRUCTION

Body	Brass
Armature tube	AISI 303
Plunger and core	AISI 430FR
Springs	AISI 302
Seal material	NBR - FPM - EPDM - PTFE



2

FEATURES

Maximum allowable pressure PS 80bar^④
 Maximum fluid viscosity 25cSt (mm²/s)
 Ambient temperature: from -10°C to +80°C according to the coil
 Universal mounting position

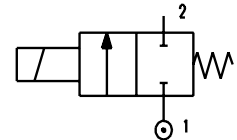

- OPTIONS:**
- Manual override
 - Electroless nickel plating
 - Stainless steel seat insert (up to Ø4.5)
 - Versions for use with industrial oxygen
 - US certified coils

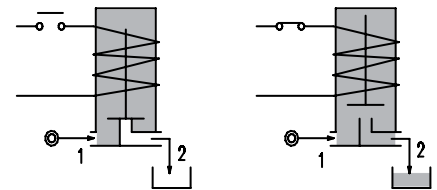

ON REQUEST: Versions for use with fluid temperature at -40°C

CODE ① ②	Connection G ISO 228	Orifice mm	Kv m ³ /h	Differential pressure bar			Nominal power			Coil		Seal ①	Temp. range °C							
				Min	Max		AC Inrush	VA Holding	DC Watt	Series	Width									
					AC	DC														
E106A...15///...	1/8"	1.5	0.07	0	30	26	20	15	10	2	30	NBR=B	-10 +90							
E106A...20///...		2	0.1	0	22	20														
E106A...25///...		2.5	0.15	0	16	14														
E106A...35///...		3.5	0.32	0	10	8														
E106B...15///...	1/4"	1.5	0.07	0	30	26								40	30	27	5	36	EPDM=E	-10 +140
E106B...20///...		2	0.1	0	22	20														
E106B...25///...		2.5	0.15	0	16	14														
E106B...35///...		3.5	0.32	0	10	8														
E106B...45///...		4.5	0.41	0	6.5	3.5														
E106B...52///...		5.2	0.47	0	4	1.8														
E106B...64///...	6.4	0.64	0	3	1															
E106A...15///...	1/8"	1.5	0.07	0	80	80													40	30
E106A...20///...		2	0.1	0	50	40														
E106A...25///...		2.5	0.15	0	35	33														
E106A...35///...		3.5	0.32	0	20	19														
E106B...15///...	1/4"	1.5	0.07	0	80	80	40	30	27	5	36	PTFE=W ③	-10 +180							
E106B...20///...		2	0.1	0	50	40														
E106B...25///...		2.5	0.15	0	35	33														
E106B...35///...		3.5	0.32	0	20	19														
E106B...45///...		4.5	0.41	0	14	13														
E106B...52///...		5.2	0.47	0	10	9														
E106B...64///...	6.4	0.64	0	5	4.5															

① Seal Example: E106BB20///20E NBR seal
 ② Coil Coil 230V 50/60Hz

③ Maximum allowable leakage <0.2NI/h

④ REMARK

The maximum allowable pressure PS for steam is 6bar (gauge pressure) with PTFE seals and 2,5bar with EPDM seals

COILS	Alternating Current 50/60Hz (V)							Direct Current (V)			Electrical connection	Connectors
	12	24	48	110	220 230	240	380	12	24	48		
Series 2 Width 30 Code ②	20A	20B	20C	20D	20E	20F	20G	200	201	202	DIN 43650A	PG9 code 10349000
Series 5 Width 36 Code ②	52A	52B	52C	52D	52E	52F	52G	520	521	522	DIN 43650A	PG11 code 10349001

DESCRIPTION
 Insulation class
 Series 2 =F Series 5=H
 Voltage tolerance
 AC +15% -10%
 DC ± 10%
 Protection class
 IP65 with connector fitted
 IP00 without connector

OPTIONS
 Class H insulation (series 2)
 Cable attached
 Special coil voltage
 Special coil powers
 US certified coils

(for more details see section 8)

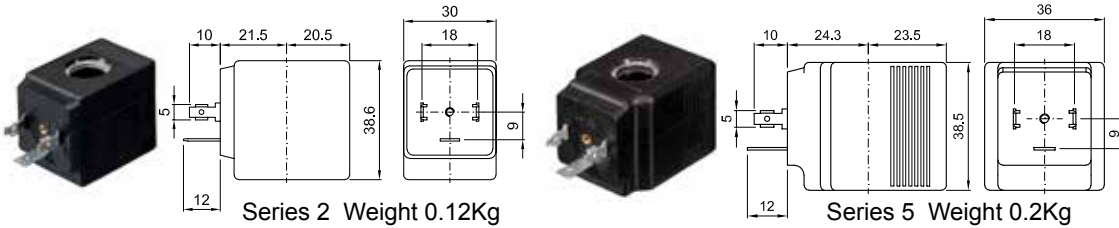

SPARE PARTS LIST

1. Coil fixing nut
2. Coil
3. Plunger
4. Armature tube assembly

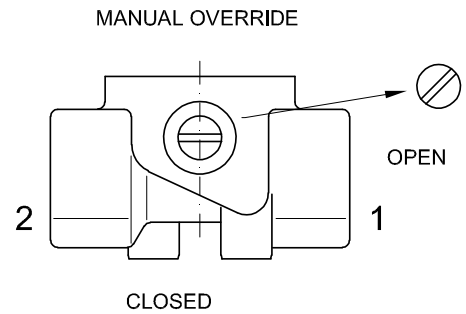
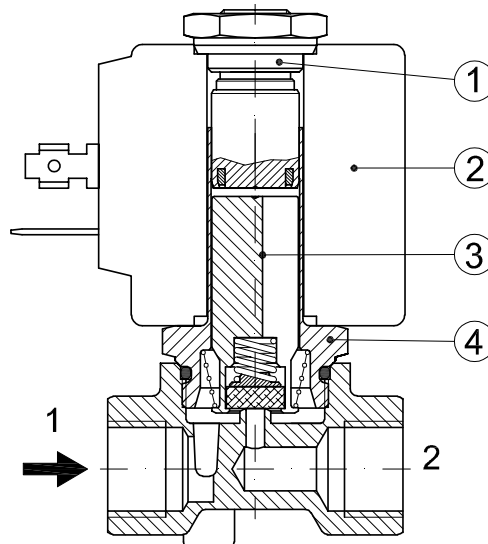

OVERALL DIMENSION

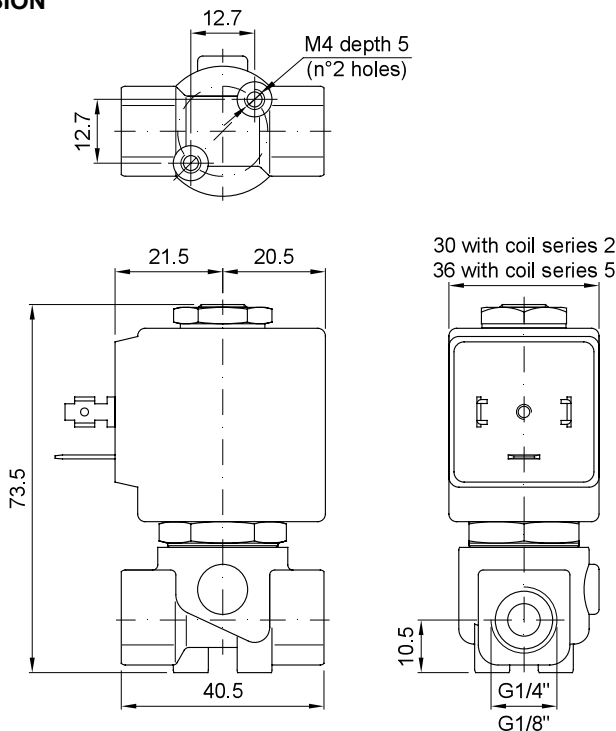

Weight with coil series 2=0.30Kg
 Weight with coil series 5=0.38Kg

DESCRIPTION

Solenoid valve 2 way normally closed
direct acting poppet type

CONSTRUCTION

Body	Brass
Armature tube	AISI 303
Plunger and core	AISI 430FR
Springs	AISI 302
Seal material	NBR - FPM - EPDM - PTFE



2

FEATURES

Maximum allowable pressure PS 80bar^④
Maximum fluid viscosity 25cSt (mm²/s)
Ambient temperature: from -10°C to +80°C according to the coil
Universal mounting position

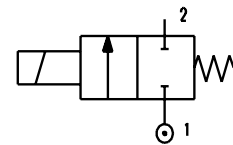

OPTIONS: Electroless nickel plating
Stainless steel seat insert (up to Ø4.5)
Versions for use with industrial oxygen
c us certified coils

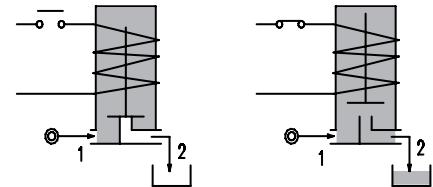

ON REQUEST: Versions for use with fluid temperature at -40°C

CODE ① ②	Connection G ISO 228	Orifice mm	Kv m ³ /h	Differential pressure bar			Nominal power			Coil		Seal ①	Temp. range °C
				Min	Max		AC Inrush	VA Holding	DC Watt	Series	Width		
					AC	DC							
E106C...30///...	3/8"	3	0.25	0	15	10	20	15	10	2	30	NBR=B	-10 +90
E106C...35///...		3.5	0.32	0	10	8							
E106C...40///...		4	0.36	0	8	5							
E106C...45///...		4.5	0.41	0	6.5	3.5							
E106C...52///...		5.2	0.47	0	4	1.8							
E106C...64///...		6.4	0.64	0	3	1							
E106D...30///...	1/2"	3	0.25	0	15	10	20	15	10	2	30	NBR=B	-10 +90
E106D...35///...		3.5	0.32	0	10	8							
E106D...40///...		4	0.36	0	8	5							
E106D...45///...		4.5	0.41	0	6.5	3.5							
E106D...52///...		5.2	0.47	0	4	1.8							
E106D...64///...		6.4	0.64	0	3	1							
E106C...30///...	3/8"	3	0.25	0	25	24	40	30	27	5	36	FPM=V	-10 +140
E106C...35///...		3.5	0.32	0	20	19							
E106C...40///...		4	0.36	0	16	15							
E106C...45///...		4.5	0.41	0	14	13							
E106C...52///...		5.2	0.47	0	10	9							
E106C...64///...		6.4	0.64	0	5	4.5							
E106D...30///...	1/2"	3	0.25	0	25	24	40	30	27	5	36	PTFE=W ③	-10 +180
E106D...35///...		3.5	0.32	0	20	19							
E106D...40///...		4	0.36	0	16	15							
E106D...45///...		4.5	0.41	0	14	13							
E106D...52///...		5.2	0.47	0	10	9							
E106D...64///...		6.4	0.64	0	5	4.5							

① Seal Example: E106CB20///20E NBR seal
② Coil Coil 230V 50/60Hz

③ Maximum allowable leakage <0.2NI/h

④ **REMARK**

The maximum allowable pressure PS for steam is 6bar (gauge pressure) with PTFE seals and 2,5bar with EPDM seals

COILS	Alternating Current 50/60Hz (V)							Direct Current (V)			Electrical connection	Connectors
	12	24	48	110	220 230	240	380	12	24	48		
Series 2 Width 30 Code ②	20A	20B	20C	20D	20E	20F	20G	200	201	202	DIN 43650A	PG9 code 10349000
Series 5 Width 36 Code ②	52A	52B	52C	52D	52E	52F	52G	520	521	522	DIN 43650A	PG11 code 10349001

DESCRIPTION
 Insulation class
 Series 2 =F Series 5=H
 Voltage tolerance
 AC +15% -10%
 DC ± 10%
 Protection class
 IP65 with connector fitted
 IP00 without connector

OPTIONS
 Class H insulation (series 2)
 Cable attached
 Special coil voltage
 Special coil powers
 US certified coils

(for more details see section 8)

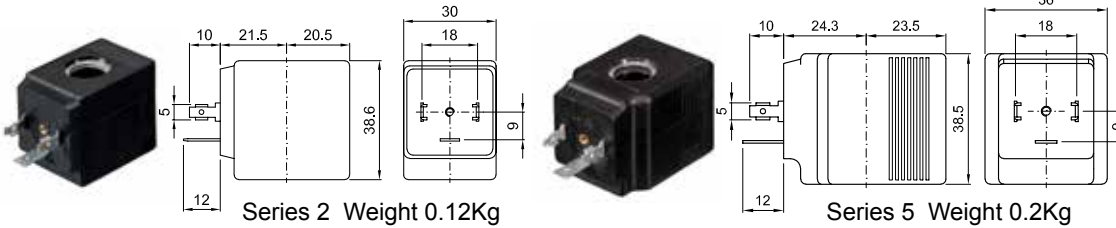

SPARE PARTS LIST

1. Coil fixing nut
2. Coil
3. Plunger
4. Armature tube assembly

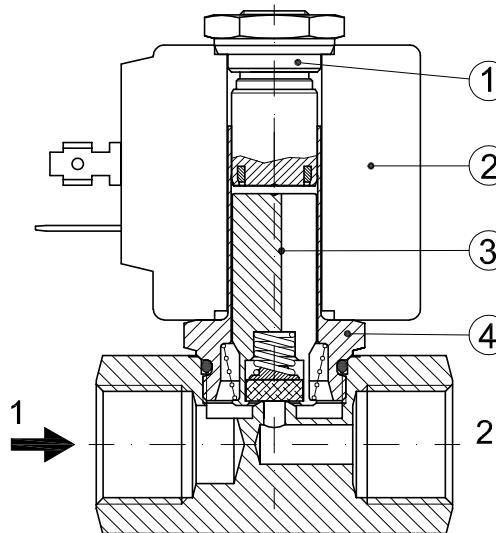

OVERALL DIMENSION

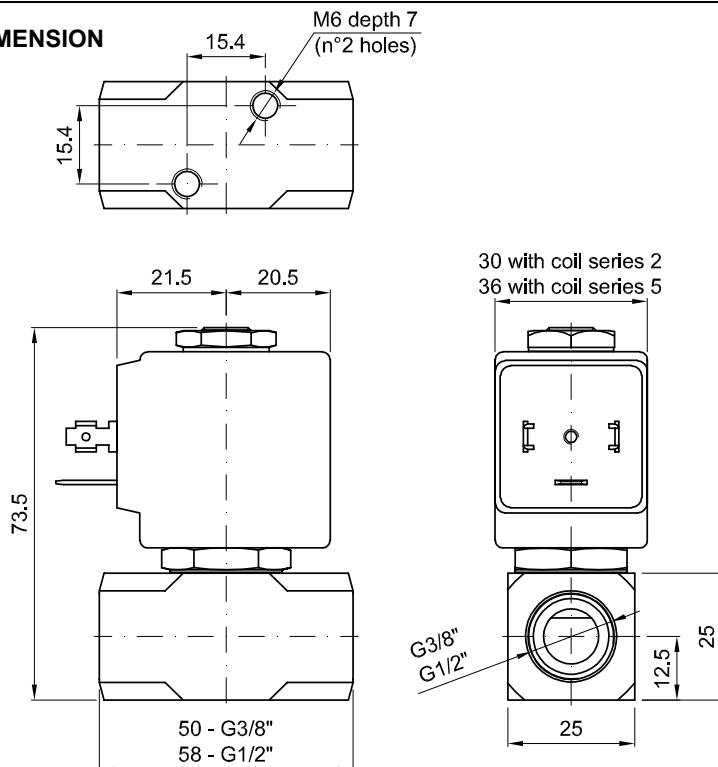

Weight with coil series 2=0.36Kg
 Weight with coil series 5=0.44Kg